

LAND DETAILS

Survey No - 1763
 Village - Vellikulangara
 Taluk - Chalakudy
 District - Thrissur
 Extent - 2.02ARE
 Nearest building number - 244-A

AREA STATEMENT

	Plinth(m ²)	Carpet(m ²)
Ground Floor	86.72	69.37
First Floor	73.66	58.92
Total	160.38	128.29

F S I : 0.79
 PERMISSIBLE F S I : 2.5
 COVERAGE : 42.93%
 PERMISSIBLE COVERAGE : 65%

JOINERY DETAILS

MD	Entrance Door	120x210	1
D1	Door	90x210	10
D2	Door	80x210	3
W1	Window	50x150	2
W3	Window	150x150	12
KW1	Kitchen Window	50x100	2
V	Ventilator	60x60	3

SPECIFICATIONS

- RRM @ 1:6 CM FOR FOUNDATION AND PLINTH
- LATERATE MASONRY @ 1:6 CM
- RCC 1:2:4 WITH 20 MM AGGRAGATE FOR LINTLES, BEAMS AND SLABS
- CC 1:2:4 WITH 20 MM AGGRAGATE FOR FLOORING
- SAND FILLING

SIG. OF LAND & BUILDING OWNER

Mr. VIJAYAN NAIR
s/o BHASKARAN NAIR
CHATHUPPELI(H)
MEKKAVE P.O
VAPPALASSERY, ERNAKULAM
PIN:683572

SIG. OF LICENCED ENGINEER

Mr. FEBIN P. F
E - DESIGN BUILDERS
ERNAKULAM, LICENCED ENGINEER
LIC:G6-1140/18/60/SA
PH : 8593020290

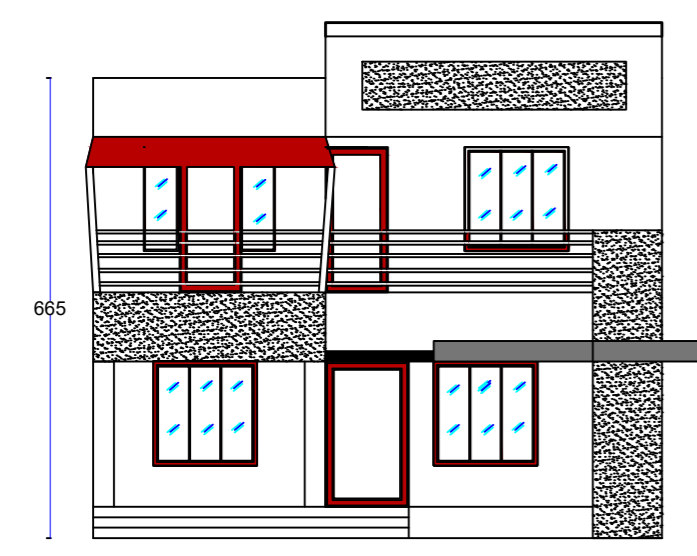

ELEVATION

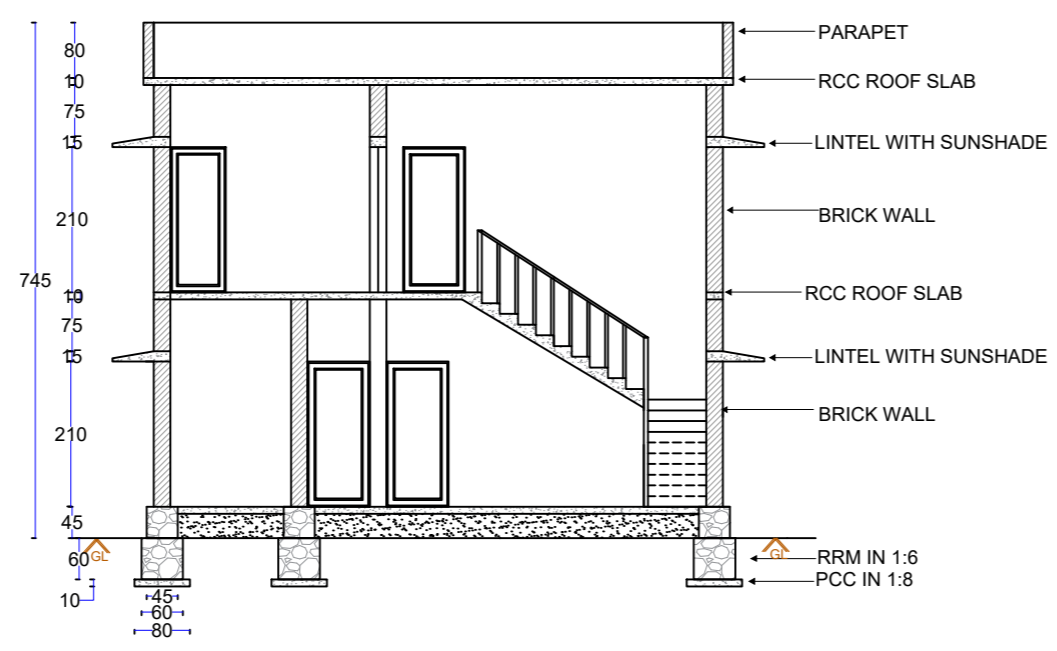

SECTION A-A - 1:100

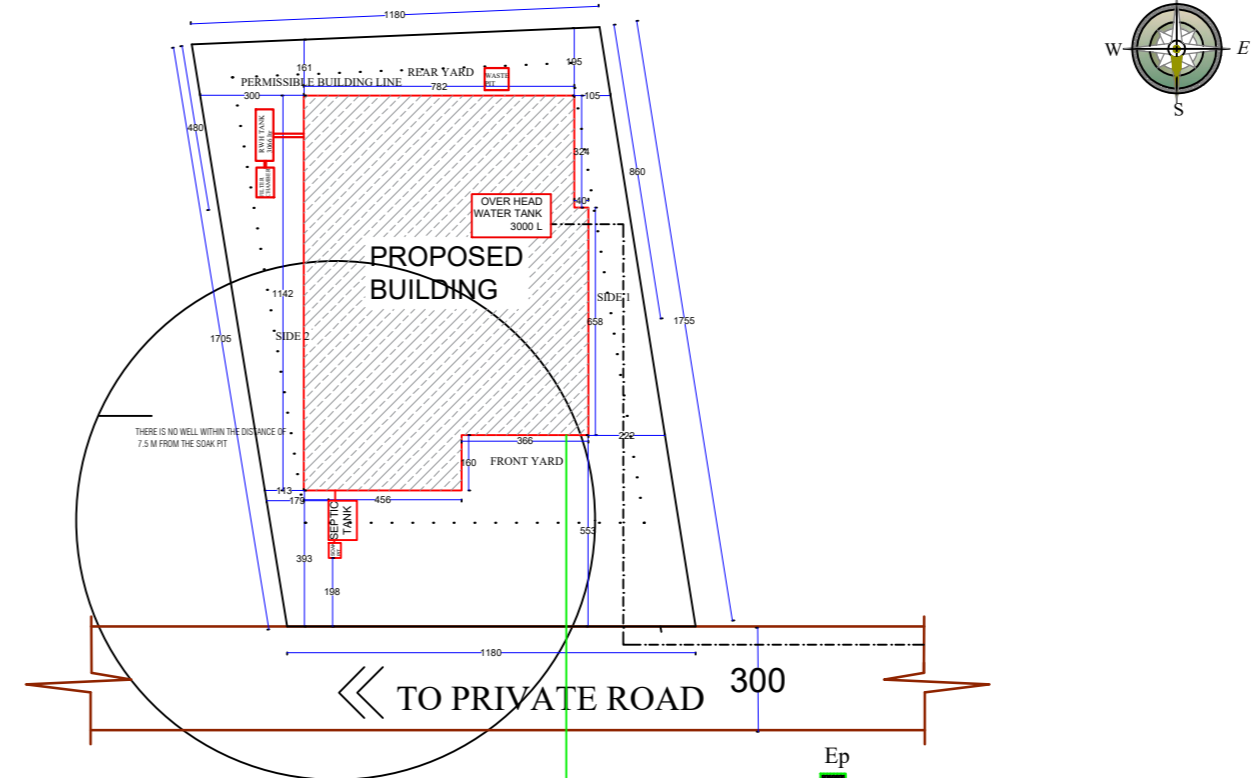

SERVICE PLAN - 1:200

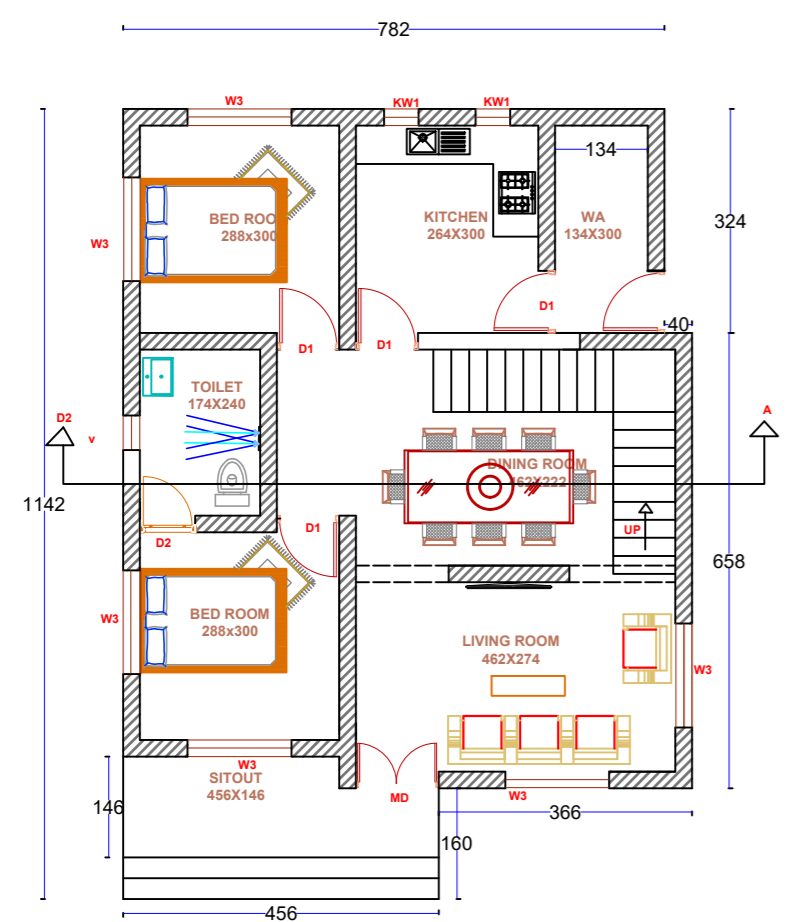

G.F PLAN - 1:100

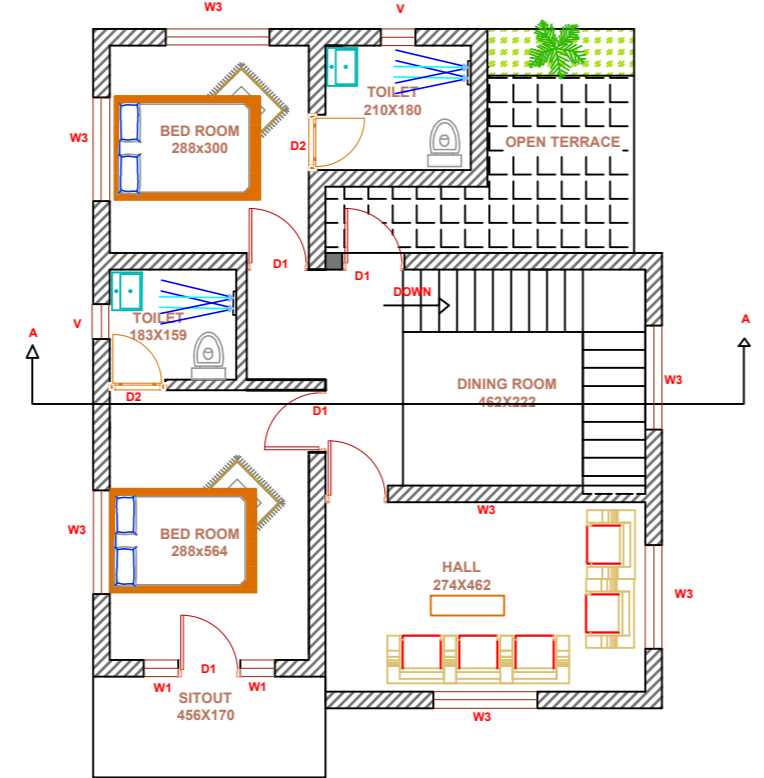

F.F PLAN - 1:100

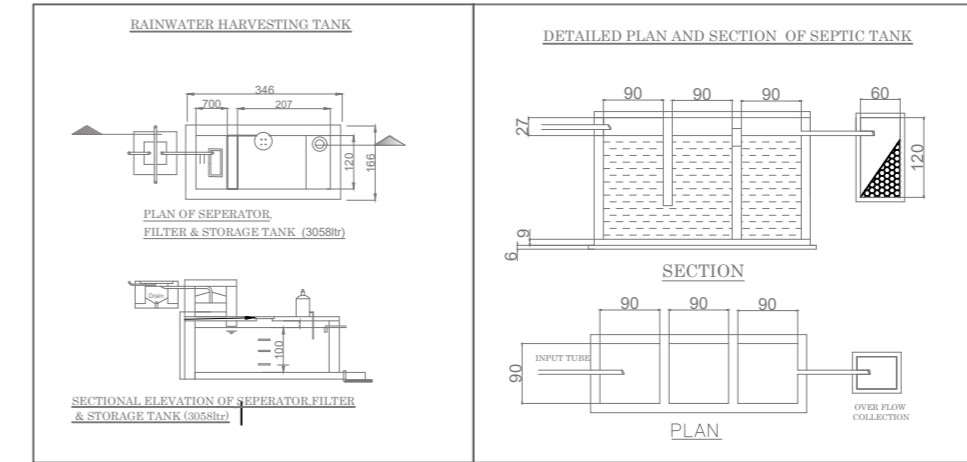

RAINWATER HARVESTING TANK (3066L) DETAILED PLAN AND SECTION OF SEPTIC TANK

COLOUR SCHEME

- PLOT LINE
- STREET
- PERMISSIBLE BL
- BUILDING PROPOSED
- DRAINS/ SEWERAGE
- ELECTRIC LINE
- WATER SUPPLY
- EXISTING BUILDING
- EXISTING BUILDING TO BE DEMOLISHED

OFFICE USE

APPENDIX-J2

ALL DIMENSIONS ARE IN CM.
 ALL DIMENSIONS ARE IN SCALE.
 UNLESS SPECIFIED AT THE DRAWINGS.

APPENDIX-J1

CERTIFICATE
 i :- the plot boundaries, measurements and other details shown in the site plan are correct and
 ii :- the drawings are in conformity with the provisions of the master plan/detailed town planning scheme / interim development order as applicable under the kerala town and country planning Act 2016.
 iii :- the drawings are in conformity with the provisions of the kerala panchayath building rules ,2019 and other applicable statutes .

CERTIFICATE
 i :- the documents (s) in support of the ownership of the plot has /have been verified and that the applicant (s) has /have every right of construction in this plot;
 ii :- the plot boundaries, measurements and other details shown in the site plan have been verified at site and found correct and
 iii :- the drawings are in conformity with the provisions of the master plan/detailed town planning scheme / interim development order as applicable under the kerala town and country planning Act 2016.
 iv :- the drawings are in conformity with the provisions of the kerala panchayath building rules ,2019 and other applicable statutes .

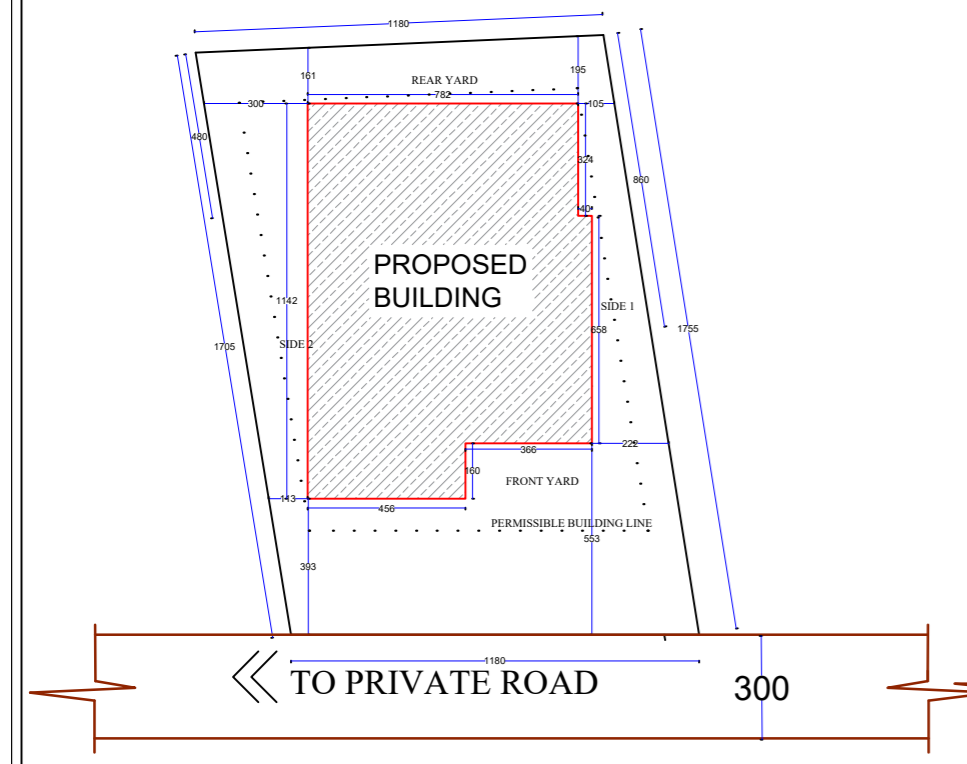

SITE PLAN - 1:200

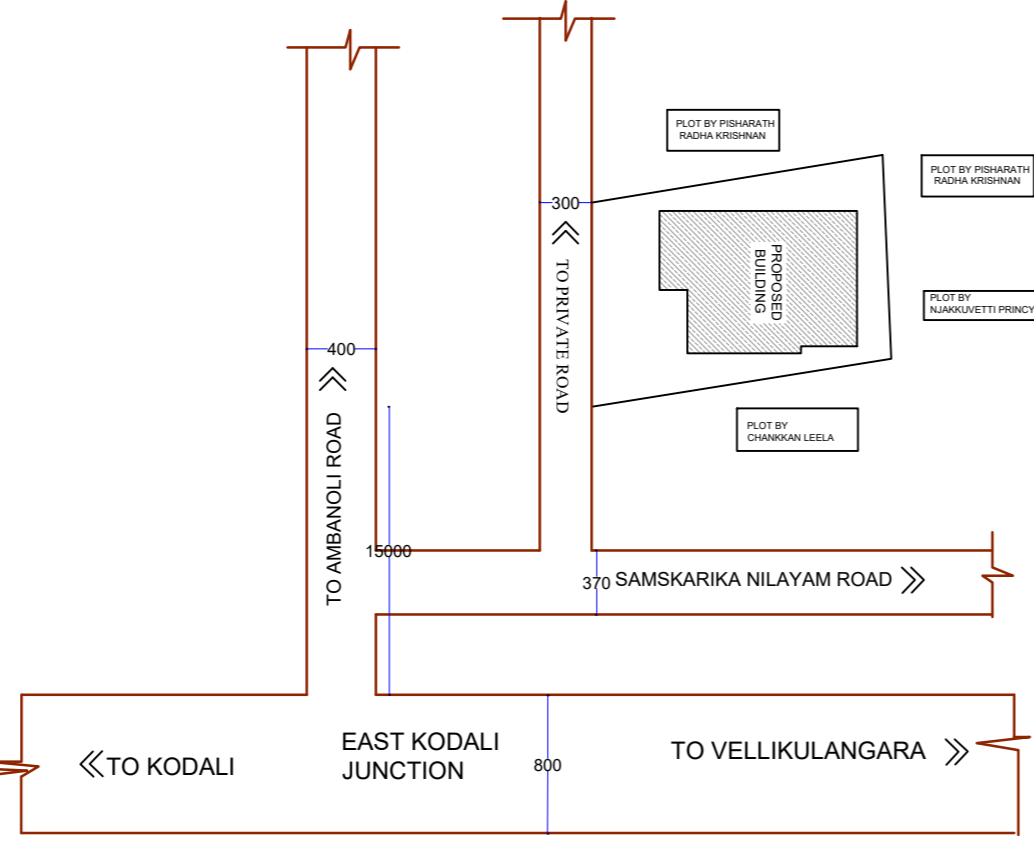

LOCATION MAP - 1:400